

MP500C-SR

Multi-Signal Spring Return Actuators for VP220x SmartX PIBCV, DN40...100



Product Description

MP500C-SR is a linear electro-mechanical actuator with a spring return function in the event of a power failure for use with the VP220 SmartX PIBCV, DN40...100.

MP500C-SR is controlled by either an increase/decrease floating signal or by a range of modulating control signals between the span of 0...10V.

Specifications

MP500C-SRU	Stem up (retract)
MP500C-SRD	Stem down (extend)
Voltage supply	24 Vac +/- 20% ±20% 50-60Hz
Power consumption	
Running	30 VA (21 W)
Rest	7 W
Running Time	
Modulating	15 sec.
Increase/decrease	60/300 sec. (selectable)
Spring return	13 sec.
Transformer Sizing	50 VA
Stroke	2...35 mm
Force, nominal	500 N
Duty cycle	20%/60 minutes (full load, high amb. temp.) 80%/60 min. (half load, room temp.)
Analog input Voltage range	0...10 Vdc
Selectable input signals	0...10, 2...10, 0...5, 2...6, 5...10, 6...10 Vdc
Impedance	Min. 100 k Ohm
Digital inputs, Y1, Y2	
Voltage across open input	24 Vac
Current through closed input	5 mA
Pulse time	min. 20 ms
Output, Y (Feedback)	2...10 Vdc or 0...5 Vdc (0-100%) - Load 2 mA
Environmental	
Operation and Storage Temperature	-10 / +50 °C
Ambient Humidity	max 90% RH
Enclosure rating	IP54
Sound power lever	43 dBa

Features

- Brushless DC motor.
- High resolution control board allows precise fluid control.
- Working range and end point switches adjusted automatically to the stroke of the valve.
- When driven electrically, firmware calibrates a consistent running time regardless of the valve stroke.
- On power loss, the mechanical spring return drives the motor, generating power to the board to control spring return braking speed, avoiding mechanical stress and system water hammer.
- Actuators can be configured for either 3 point increase/decrease signal or various modulating control signals including sequencing.
- The U-Bolt connection allows quick and easy direct mounting onto the SmartX PIBCV VP220 valves.

Standards	
Emission/Immunity	EMC 2004/108/CE according to EN 61326-1:2006
Heat	IEC-68-2-2
Humidity	IEC-68-2-3
Cold	IEC-68-2-1
Vibration	IEC-68-2-6
Materials	
Max cable core diameter	2.5 mm ²
Direct connection to Smart X PIBCV valves	VP220, DN40...100
S2 Auxillary Switch Relay (optional accessory)	SPDT, 24 Vac 4A AC1 (contacts made at 5% and 95% of end stroke)
Weight	2.8 Kg

Part Numbers & Accessories

Part Number	Spring Return Direction	Function on Power Failure
MP500C-SRU	Spring return stem up	Valve Open
MP500C-SRD	Spring return stem down	Valve Closed
880-0104-000	S2 auxiliary end point switches	

Dimensions (mm)

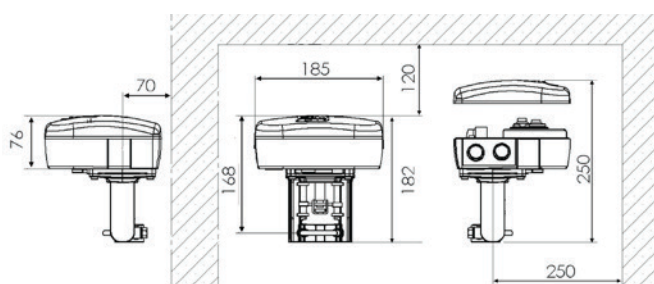

Function

Actuator

The actuator utilizes a brushless DC motor to accurately position the main spindle via a gearbox depending on the control signal received from the controller. Upon initial start up the and self stroking activation (operation of switch 9) the actuator performs a full stroke cycle to learn the valve end stop positions and to calibrate the motor speed and actuator full stroke running time. End switch point adjustment is also calibrated during this process. In case of power failure the actuator is equipped with spring return function which returns the valve and actuator back to the rest position. The actuator cannot be configured or modified between spring return stem up and spring return stem down.

Control Signal

MP500C-SR actuator can either be controlled by an increase/decrease signal or by a variable direct voltage. The actuator is very flexible regarding the configuration of signal input and a direct or inverse actuation but normally for an increase/decrease the actuator retracts (moves up) on an increase signal and extends (moves down) on a decrease signal.

Spring Pretension

To ensure tight shut off from an assembled SR actuator and control valve for closure on spring return function, it is necessary during installation to align the actuator spindle with the required valve stroke and stroke limits. Refer to Installation Instructions F-27943.

Position Feedback

MP500C-SR actuators are equipped with a 2...10 Vdc and 0...5 Vdc position feedback signal selectable by Sw 1.

End Point Switch (Accessory)

When fitted, the End Point Switch (S2 Auxiliary Switch relay) is calibrated during the initial stroke learning procedure. The switch points electronically make at 5% and 95% of the calibrated stroke position. When actuators are controlled in normal or sequence control it is possible to use the end point switches to drive other equipment or to signal if the valve is fully open or fully closed.

Maintenance

The actuator does not require any maintenance.

Mounting and Installation

Note the presence of an O-ring in the cover of the actuator and ensure it is in position as the cover is removed and replaced. The actuator may be mounted in any position other than upside down.

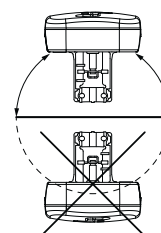

Maximum actuator ambient temperature is 50 °C (122 °F) for chilled water media. Maximum actuator ambient temperature is 46° C (115° F) when media temperature is 120° C (248° F).

Mounting the Actuator to the Valve

To mount the actuator to a valve, first slide the Actuator Crossbeam Coupler into position on the actuator cross beam bracket. Separately, slide the Valve Stem Coupler onto the Valve Stem. Maintaining the couplers in their positions, slide the actuator onto the valve stem then slide the U-bolt into the actuator groove on the valve neck, securing with nuts provided. Driving the crossbeam coupler down into the valve coupler completes the installation and a “click” sound may be heard as the Valve Coupler locking ring engages the Actuator Crossbeam Coupler.

Manual Operation

To operate the manual override power to the actuator must be disconnected. The manual override procedure allows the actuator to be positioned independently of control signal and can be operated with or without the cover attached. The operating direction of both the manual override and lock screw are clearly labelled on both the cover and inside the actuator, and these labels differ based on if the actuator is purchased SRU or SRD.

Manual override is conducted by using a 5mm hex (Allen) key either S-shaped, L-shaped or T-shaped tool. The action of the manual override is always against the spring tension. The actuator spindle position can be locked against the spring by twisting the lock screw in the direction as shown on the actuator.

The manual override lock should only be released either by nudging the manual override by 10° in the normal direction (against the spring), or re-applying power/control signal to the actuator. When the actuator is first powered on it will momentarily drive against the spring to release the manual override lock before being driven by an external control signal. If the hex key is left in the hex manual override drive socket, the hex key will rotate as the actuator is driven. This is not recommended and damage could occur if the key is not free to rotate.

1. Manual override drive socket (5mm hex)
2. Lock screw, flat screwdriver slot

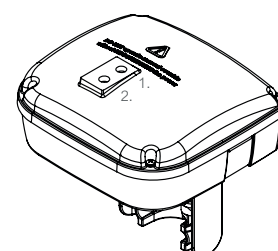

Agency Listings

Underwriters Laboratory (E9429) compliance as Temperature Indicating & Regulatory Equipment cULus LISTED per UL873 and Canadian Standard C22.2 No. 24. European Community compliance per EMC directive (2014/30/EU) and LVD directive (2014/35/EU). Australian/New Zealand community RCM mark.

Electrical Connections

Terminal	Function	Description
24~	24 Vac	Supply voltage
⊥24	Ground	
Y	Input	Modulating Control signal
M	Input, neutral	
Y2	Increase	3-point Floating/Digital input control (Y1, Y2 connected to ⊥24)
Y1	Decrease	
U	0...100% (2...10 Vdc)	Feedback signal (reference to ⊥24)

Cable Lengths

24~, ⊥24= Max 100 m, 1.5 mm² (AWG 15)
 Y, M, Y, Y1, Y1 = Max 200 m 0.5 mm² (AWG 20)

NOTE: When installed with 3 conductors, where the control signal reference is connected to ⊥24, the motor current of the actuator will cause varying voltage loss in the cable and thus in the reference level. The MP500C-SR has a highly sensitive control circuitry which can be influenced by interference in the control signal which the actuator can try to follow. This influence may be reduced in simple installations by shortening the cable lengths below 100m and /or increasing the cross sectional area of the cable above 1.5mm² (AWG 16) and the cables are spured to only one actuator.

Connections/PCB Layout

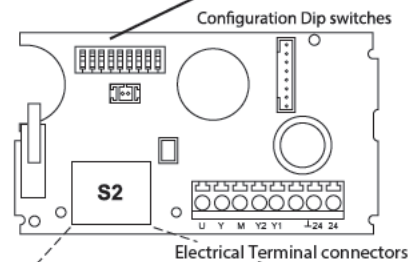
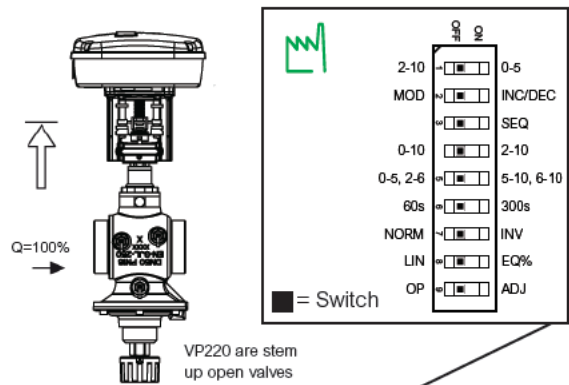
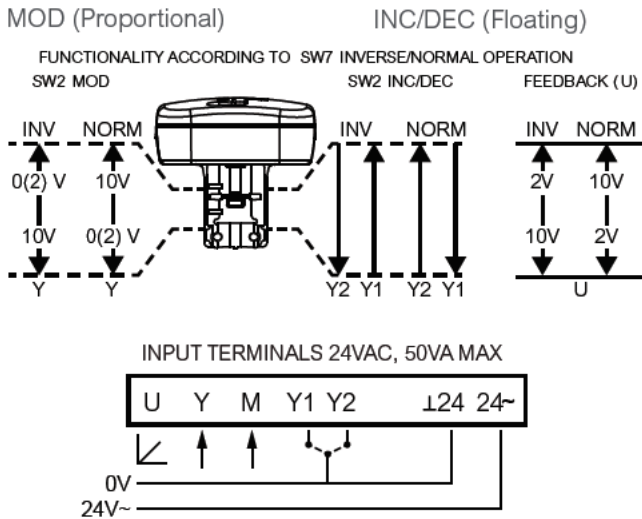

Wiring Examples

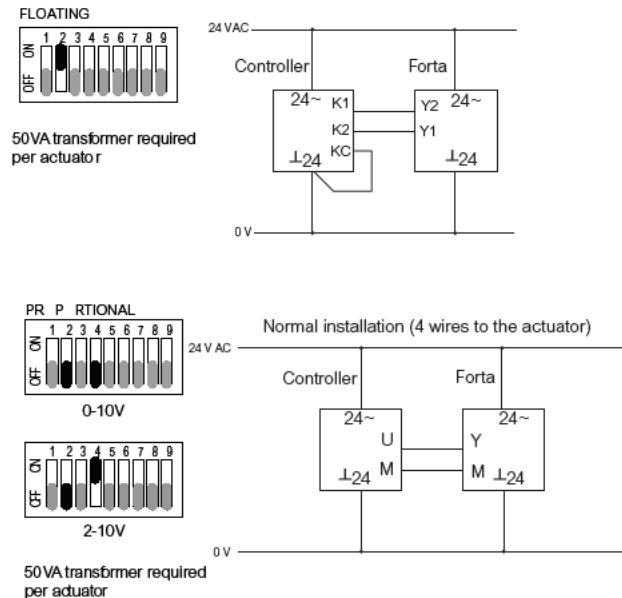

S2 Auxiliary Switch unit, accessory

KC1 to K1 closes upon a fully closed valve.
 KC2 to K4 opens upon a fully open valve.

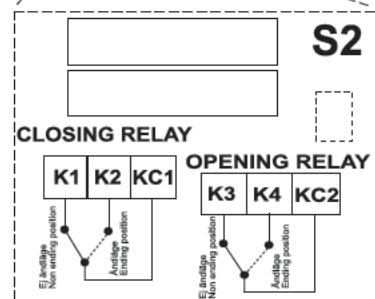

Dip Switch Settings

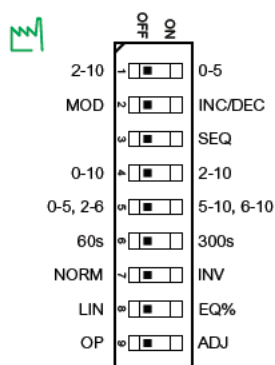

■ = Switch

Sw	Description	Off Position	On Position
1	Feedback signal	2...10 Vdc	0...5 Vdc
2	Control mode	Modulating (proportional) signal	Increase / Decrease (Floating signal)
3	Sequence operation	--- Normal operation (no sequencing)	SEQ. SW 2 off, SW 3 on, SW 4 select base range (0 10 or 2...10) SW 5 select sequence range.
4	Input voltage range	0 10 Vdc	2 10 Vdc
5	Operational Working voltage range (if SW3, SEQ selected)	0 5 Vdc or 2 6 Vdc	5 10 Vdc or 6 10 Vdc
6	Running time (Increase/decrease control only)	60 sec.	300 sec.
7	Direction of movement	NORM. Actuator spindle extends downwards with a decreasing control signal. (Normal operation for VP220x PIBCV)	INV. Actuator spindle retracts upwards with a decreasing control signal
8	Linearization	Linear Flow (Normal)	EQ
9	Stroke Calibration	OP (Normal operation)	ADJ. Calibrate valve stroke limits

There is a 9 switch configuration block on the circuit board. The factory setting is all switches in the "OFF" position. Adjust these settings prior to engaging power and any subsequent changes to the DIP switches will not be registered until the power is interrupted, or when switch No. 9 is initiated (End position adjustment) causing a re-calibration of the actuator and valve assembly.

- **SW1 Feedback signal.** Select between 2...10 V and 0...5 V feedback voltage output.
- **SW2 Control signal MOD / INC.** MP500C-SR is either controlled by a variable direct voltage, for a modulating signal (MOD), or by a 3-point increase/decrease signal (INC).
- **SW3 Sequence or parallel control – / SEQ.** With sequence (or parallel) control (SEQ), two actuators/valves can be controlled by only one control signal. Depending on Switch 4 and 5, you can choose which part of the voltage range to use, the upper one, 5...10 V (6...10 V) or the lower one, 0...5 V (2...6 V). Note: If sequence or parallel control is not used, the switch --- / SEQ must be in the OFF position.
- **SW4 Input Voltage range 0...10 / 2...10.** You can choose whether to use the control signal voltage range 0...10 V or 2...10 V.
- **SW5 (0...5, 2...6 / 5...10, 6...10).** When switch 3 (SEQ) is ON choose the operational voltage range.
 - OFF: low: 0...5 V (2...6 V)
 - ON: high: 5...10 V (6...10 V)
 The bracketed control voltage is operational with switch 4 ON.
- **SW6 Running time 60 s / 300 s.** On increase/decrease control, this switch selects the running time between 60 s (Off) or 300 s (On). With modulating control, the running time is always 15 s.
- **SW7 Direction of movement NORM / INV.** The Norm / INV switch reverses the actuator direction of movement relative to signal change.
 - With the switch in the NORM position, the actuator spindle moves down when the signal decreases, this closes the VP220x on a 0V control signal).
 - With the switch in the INV, the actuator spindle moves up when the signal decreases. Thus on the VP220x valve, this setting will provide an open valve on 0V control signal).
- **SW8 Linearization LIN/EQ.** The motorized valve characteristics can be modified. The setting LIN/EQ will make the VP220x Valve from a linear flow characteristics to an equal percentage.
- **SW9 Input signal and stroke Calibration OP / ADJ.**
 - This switch is only used to calibrate the stroke end positions.
 - To initiate, momentarily move the switch to the ON position then back to the OFF position. At the end of the adjustment all the other dip switch settings (1 to 8) will be registered again.